

CERIF: Common European Research Information Format

Formal Contextual Relations to guide through the Maze of Research Information

Brigitte Jörg

German Research Center for Artificial Intelligence,
Language Technology Lab, Saarbrücken, Germany

brigitte.joerg@dfki.de

Abstract: Research Information as an asset is gaining ground with recent developments in national assessment and performance exercises, where evaluation methods often depend upon structured and integrated data and where data quality becomes an issue. Not only at national level but also at a European scale Research Information is being recognized as a player to grant access to scientific knowledge and as an enabler for large-scale data integration and data management. With this paper we present the power of the CERIF model to manage Research Information in a timely context by applying formal semantics in relationships.

1. Introduction

Research Information as an asset is gaining ground with recent developments in national assessment and performance exercises, where evaluation methods often depend upon structured and integrated data and where data quality becomes an issue [Asserson and Simons 2006, Bosnjak and Stempfhuber 2008]. Not only at national level but also at a European scale Research Information is being recognized as a player alongside publication repositories to grant access to scientific knowledge [Driver 2008] and as an enabler for large-scale data integration and data management [Joint 2008, Carpenter 2008]. Most European countries collect and store their research information in digital repositories; these may be national, regional, institutional, functional, or thematic in their range, where each system builds upon a particular format or structure to serve for special requests. In order to get additional value out of related information and knowledge contained in distributed systems their data have to be integrated. That is, the structures and formats have to be mapped towards an agreed format within a target system for further analysis. Data integration is not an easy task, difficult at the national level and quite a challenge at the European scale [Jörg et al 2008] and beyond. However, access to scientific knowledge and current research information is an essential requirement in the ERA¹, for innovators, academics, decision makers, media, and the members of the society in general. It is realized that research and development leads to wealth creation and improvement in the quality of life, and because public funding is involved, it is necessary for there to be appropriate governance and also for the information to be available to the public.

CRIS and CERIF approaches into this direction are not new [Asserson et al 2002]. In the 1970s serious efforts for international cooperation among research information systems were being made to survey a country's scientific and technological potential, and to use such information in the formulation of science policy on a national level². In 1971, Unisist³ published a "Study report on the feasibility of a world science

¹ European Research Area (ERA): http://ec.europa.eu/research/era/index_en.html

² CORDIS comprehensive information about CERIF, CRISs and their history: <http://cordis.europa.eu/cerif/>

³ UNISIST: Unesco's World Scientific Information Programme

information system” [Unisist 1971]. In 1987 the European Working Group on Research Databases held a workshop, and as a result recommended CERIF to be used as a standard format to permit exchange of records between different member countries and to serve as a basis for setting up a network between research databases.

Each nation state has similar research processes: strategic planning; program announcement; call for proposals; proposal evaluation and awarding; project result monitoring; project result exploitation. However, research is international. A research project in country A is likely based on previous research in several other countries. Many research projects are transnational. Knowledge about the research activity in country A may influence the strategy towards the research – including priorities and resources provided – in country B. Thus, there is a need to share research information across countries, or even between different funding agencies in the same country. Research Information is used by researchers (to find partners, to track competitors, to form collaborations); research managers (to assess performance and research outputs and to find reviewers for research proposals); research strategists (to decide on priorities and resourcing compared with other countries); publication editors (to find reviewers and potential authors); intermediaries/brokers (to find research products and ideas that can be carried forward with knowledge/technology transfer to wealth creation); the media (to communicate results of R&D in a socio-economic context) and the general public (for interest). Research Information is relevant for actors in scientific environments as well as for decision makers to support related organization, management and planning. We consider Research Information as the transmitter between Science and Society and as such as a powerful instrument for governance. Having such an impact, Research Information has to be collected carefully and preserved systematically, in order to most effectively support society and the individuals within [EuroHORCS 2008].

2. Current Research Information Systems (CRISs)

Research information is managed in research information systems. They allow for a coherent view over information about research actors, their activities and their environments [Jeffery and Asserson 2006a].

Some questions that may be answered from a CRIS are:

- Which related project exists within the research group or organization or scientific network researcher X is part of?
- By which funding agencies or sponsors is research project C financed?
- How often have articles by author X been cited?
- Did author X publish with institutionally external authors?
- In how many FP7 projects does organization Z participate?
- How many publications have resulted from project Y?
- How many women have been involved in FP6 projects?

Research Information Systems are built upon a conceptual domain model, to capture the meaning of a domain and to structure the domain into entities and their relationships [Wand and Weber 2002]. As entities we consider the objects relevant in a domain, such as Person, Project, Organization, Publication, Patent, Product, Funding, or Equipment for the research domain. An entity can be represented by

attributes and by the relationships it maintains with other entities at a time. The relevant entities, their attribute and relationship descriptions as such compose the model of a domain for setting up a particular information system. We preferably talk of *Current* Research Information Systems (CRISs) to indicate their dynamics and timeliness [Jeffery and Asserson 2006b].

3. Common European Research Information Format (CERIF)

CRIS activities and developments in Europe are tightly interrelated with CERIF. CERIF is considered a standard recommended by the European Union to its Member States⁴, that has been developed with support of the European Commission in two major phases: 1987-1990 and 1997-1999. The first release of CERIF has been published in 1991. Its structure was based on a data model that originated in the eighties, describing research projects. In 1997, revision work was entrusted to unit D2 DG XIII of the European Commission, and the resulting model included many more entities relevant in the research context, such as Person, Organization, and Publication and led to a recommendation for CERIF 2000 to the Member States and a handover of CERIF to euroCRIS⁵. Since then, the CERIF model and standard has been further developed, with latest releases to include a Semantic Layer and an XML-based data interchange format [Joerg et al 2009].

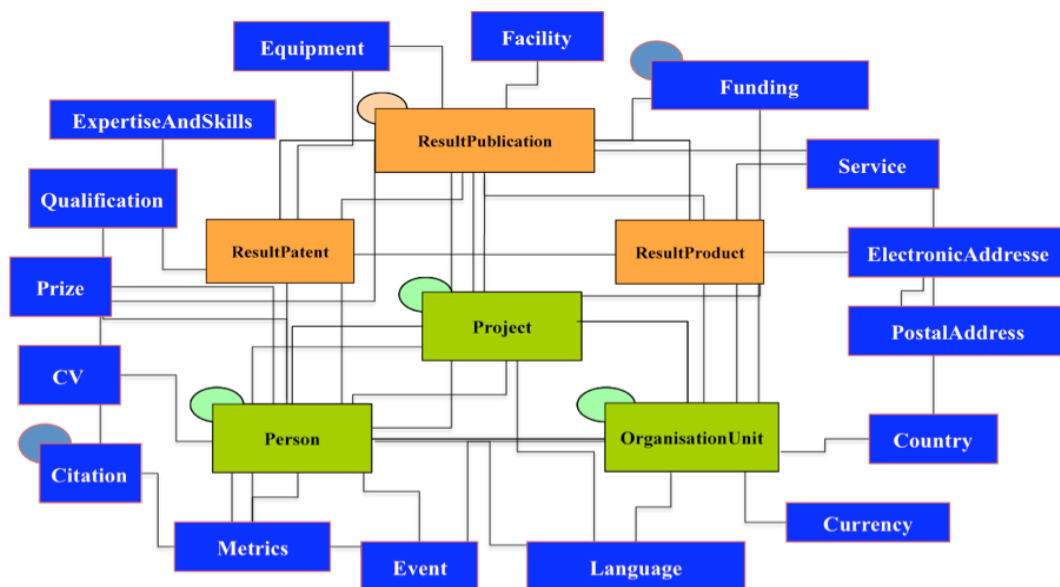

Figure 1: CERIF Entities and their Relationships in abstract view

The physical CERIF model is a relational database model available as SQL scripts based on common ERM (Entity Relationship Model) constructs [Chen 1976]. Figure 1 shows the CERIF entities considered relevant to represent the research domain and some of the relationships between them. The CERIF model will now be introduced, giving emphasis to its solution with managing relationships by applying a formal semantics in a timely context.

⁴ CERIF: <http://cordis.europa.eu/cerif/>

⁵ euroCRIS: <http://www.eurocris.org/>

3.1 The CERIF Entities and Features

The CERIF model can be conceptually structured into entity types and features. In between the types we distinguish core, result, link and 2nd level entities. As features we consider multilinguality and semantics.

- **CERIF Core Entities [core]:** The core entities are Person, OrganisationUnit and Project. Figure 1 shows the core entities in the bottom center, indicating their recursive (circles) and linking relationships. Each core entity links to itself and maintains relationships with other entities. Core entities allow for the representation of scientific actors.
- **CERIF Result Entities [result]:** The result entities are ResultPublication, ResultPatent and ResultProduct. Figure 1 shows the result entities in the upper center indicating their linking relationships. Additionally, the ResultPublication entity like a core entity recursively links to itself. Result entities allow for the representation of research output.
- **CERIF 2nd Level Entities [2nd]:** Some 2nd level entities are Funding, Facility, Equipment, Prize, CV, Expertise, Qualification, Citation, Metrics, Event, Postal and Electronic Address. Figure 1 shows the 2nd level entities for a representation of the environment of core and result entities.
- **CERIF Link Entities [link]:** Link entities are the reified relationships between core, result and 2nd level entities. They are considered a major strength of the CERIF model. A link entity always connects two entities. Each link entity instance or record requires a timestamped reference to a classifier which is itself assigned to a classification scheme.

cfEntity1Name_Entity2Name	
cfInheritedEntity1Identifier cfInheritedEntity2Identifier	(PFK) (PFK)
cfInheritedClassificationIdentifier cfInheritedClassificationSchemeIdentifier	(PFK) (PFK)
cfStartDate cfEndDate	Timestamp Timestamp

Figure 2: Meta structure of the physical representation of CERIF Link Entities

Figure 2 shows the meta structure of physical CERIF link entities. The physical name of link entities is composed by the names of the two involved entities, including a CERIF prefix (cfEntity1Name_Entity2Name). The order of the linked entity names implies the order of the inherited identifier attributes establishing the physical linkage of instances or records. Each link entity instance carries a formal semantics by reference (cfInheritedClassificationIdentifier, cfInheritedClassificationSchemeIdentifier) to the Semantic Layer enhanced by timestamps. The entity identifiers plus the classification identifiers and the timestamps compose the primary key of link entities. Table 1 shows example records of link entities.

Table 1: CERIF Link Entity Example Records including formal semantics

			Semantic Layer			
Link Entity Name	Inherited Entity1 Identifier	Inherited Entity2 Identifier	Inherited Classification Identifier	Inherited Classification Scheme Identifier	Start Date	End Date
cfOrgUnit_OrgUnit	orga-id1	orga-id2	has part	Organisation Structure	2000-01-01	2008-12-31
cfPers_OrgUnit	pers-id1	orga-id2	is head of	Organisation-Person Roles	2000-01-01	2008-12-31
cfPers_Proj	pers-id2	proj-id1	is participant of	Project-Person Roles	2001-04-01	2004-03-31
cfPers_Proj	pers-id2	proj-id1	is coordinator of	Project-Person Roles	2001-04-01	2004-03-31
cfPers_ResPubl	pers-id1	publ-id1	is author of	Publication-Person Roles	2009-04-23	2009-04-23
cfResPubl_ResPubl	publ-id1	publ-id1	is selfcitation of	Publication-Citation Roles	2007-01-01	2007-01-01
cfProj_Fund	proj-id1	fund-id1	is funded by	Project-Funding Roles	2001-04-01	2004-03-31

Each record in a link table carries the semantics of the linkage by reference to the Semantic Layer. The example records show that there may exist many formal semantic classification schemes for specific needs, i.e. „Organisation Structure“, „Organisation-Person Roles“, „Project-Person Roles“, „Publication-Person Roles“. Each classifier requires assignment to a particular classification scheme. In the examples, the „has part“ classifier is assigned to the scheme „Organisation Structure“; the classifier „is head of“ belongs to the „Organisation-Person Roles“.

Whereas link entities only carry formal semantics, because they solely store ids, the real semantic values or classifiers including their scheme assignments are maintained and stored within the CERIF Semantic Layer explained below.

- **CERIF Multilingual Features [lang]:** Much information in the research domain needs a representation in more than one language. The support of multilingual features is very important in countries where several official languages are spoken and maintained. CERIF supports multiple language features for names, titles, descriptions, keywords, abstract and even for the semantics.
- **CERIF Semantic Features (Semantic Layer) [class]:** The so called Semantic Layer allows for the representation of relationship kinds [Storey 1993; Wang et al 1999], application views, subject classifications, or any classification scheme or mapping in between schemes. The Semantic Layer can be considered as container to manage and maintain the formal semantics required in different contexts.

The presented conceptual structure of CERIF types and features is only a virtual structure, and as such not inherent in the physical data model. The conceptual structure has been introduced to support understanding of the model and follows the CERIF 2008 – 1.0: Model Introduction and Specification [Joerg et. al. 2009].

3.2 The CERIF Semantic Layer in some detail

The CERIF Semantic Layer is a simple but powerful instrument. It supplies the means to maintain the formal contextual semantics: any types, roles, terminology, subject classifiers or mappings at a time. It stores the semantic values that are carried by link entities via the classifier attribute (cfClassSchemeId) references, and it assigns each semantic value to a particular classification scheme (cfClassSchemeId), thus allowing for the representation of various relationship kinds. The CERIF Semantic Layer is physically constructed by the entities shown in figure 3.

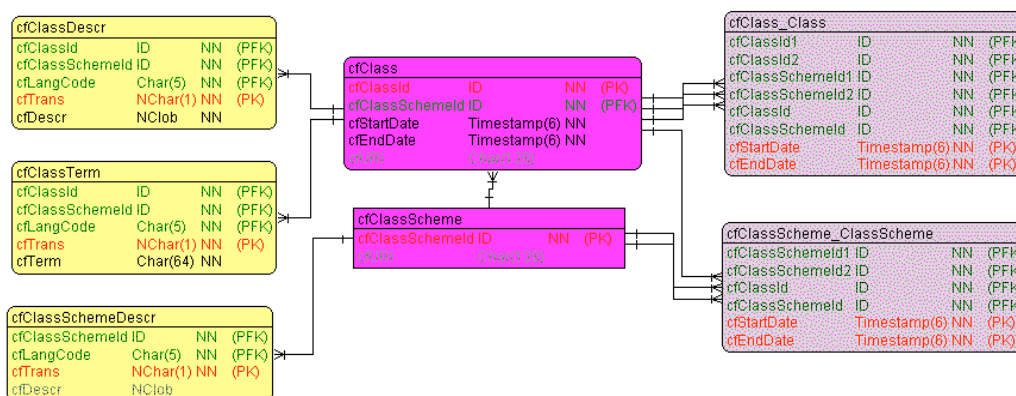

Figure 3: CERIF Semantic Layer in ERM physical view*

The Semantic Layer consists of the two class type entities classification (cfClass), and classification scheme (cfClassScheme). Additionally, it allows for a representation of multilingual terms (cfClassTerm) and descriptions (cfClassDescr). The two class type entities (cfClass, cfClassScheme) are inter-connected by two recursive link entities (cfClass_Class, cfClassScheme_ClassScheme) to allow for the representation of any structure. The records in table 2 show formal semantic records including some of the publication types and roles from the latest CERIF Semantics [Joerg et al 2009a].

Table 2: CERIF Semantic Layer examples

cfClassId	cfTerm [cfLangCode=en]	cfClassDescr	Link Entity	cfClass SchemeId
class-1	Book	A book is a ...	cfResPubl Class	CERIF2008-Publ-Types
class-2	Book Review	A book review is a ...	cfResPubl Class	CERIF2008-Publ-Types
class-3	Book Chapter Abstract	A book chapter is a ...	cfResPubl Class	CERIF2008-Publ-Types
class-4	Book Chapter Review	A book chapter review	cfResPubl Class	CERIF2008-Publ-Types
class-5	Inbook		cfResPubl Class	CERIF2008-Publ-Types
class-6	Anthology		cfResPubl Class	CERIF2008-Publ-Types
class-10	is author of		cfPers ResPubl	CERIF2008-Pers-Publ-Roles
class-11	is author (numbered) of		cfPers ResPubl	CERIF2008-Pers-Publ-Roles
class-12	is author (percentage) of		cfPers ResPubl	CERIF2008-Pers-Publ-Roles
class-13	is editor (numbered) of		cfPers ResPubl	CERIF2008-Pers-Publ-Roles
class-14	is editor of		cfPers ResPubl	CERIF2008-Pers-Publ-Roles
class-15	is reviewer of		cfPers ResPubl	CERIF2008-Pers-Publ-Roles
class-20	is synonym of	synonym relation	cfClass_Class	Thesaurus Relationships
class-21	is broader than	broader term relation	cfClass_Class	Thesaurus-Relationships
class-22	is narrower than	narrower term relation	cfClass_Class	Thesaurus-Relationships

* Because in some databases the length of a table name is restricted to a particular number of characters, we have shortened the physical table names to ensure the consistency of SQL scripts by avoiding uncontrolled truncations.

The CERIF link entities with their reference mechanism to the Semantic Layer are considered a major strength of the CERIF model. This linkage is consistent across entities as demonstrated below with example records for project and publication.

3.3 Some CERIF example Records with Formal Semantics

Table 3 shows a CERIF project record where common and multilingual attributes are stored in the upper rows, and the lower rows show their relationships (link entities), including a formal contextual semantics. The linkage is established by ids (cfClassId, cfResPublId, cfOrgUnitId, cfFundProgId) as indicated in the attribute column. The type column indicates the entity type (core, link, lang), the formal semantic values (2004-IST-3, is originator of, is coordinated by, is funded by) are stored in the classification column where each value belongs to a scheme (FP6-IST, PROJ-PUBL, PROJ-ORG, PROJ-FUND).

Table 3: CERIF Project Example Record

CERIF Project example database entry	Entity/Table	Type	Attribute	Semantic Layer (CERIF Semantics)	
				Classification (ClassIds)	Classification Scheme
project-ist-world	cfProj	core	cfProjId		
IST World	cfProj	core	cfAcro		
http://www.ist-world.org/	cfProj	core	cfURI		
2005-04-01	cfProj	core	cfStartDate		
2007-11-30	cfProj	core	cfEndDate		
Knowledge Base for RTD Competencies in IST	cfProjTitle	lang[en,o]	cfTitle		
Wissensbasis für RTD Kompetenzen im Bereich IST	cfProjTitle	lang[de,h]	cfTitle		
IST, Research Information, NMS, Portal, Information System	cfProjKeyw	lang[en.o]	cfKeyw		
The objective of the project is to set up and populate an information portal with innovative functionalities that helps to promote RTD competencies in IST in the New Member States (NMS) and Associate Candidate Countries (ACC) in order ...	cfProjAbstr	lang[en.o]	cfAbstr		
classification-2004-ist-3	cfProj_Class	link	cfClassId	2004-IST-3	FP6-IST
publication-analyzing-european- research-competencies-in-ist	cfProj_ResPubl	link	cfResPublId	is originator of	PROJ-PUBL
publication-cris-information- systems-for-research-activity	cfProj_ResPubl	link	cfResPublId	is originator of	PROJ-PUBL
publication-analytic-services-for- the-era-publication	cfProj_ResPubl	link	cfResPublId	is originator of	PROJ-PUBL
organisation-dfki	cfProj_OrgUnit	link	cfOrgUnitId	is coordinated by	PROJ-ORG
funding-programme-fp6	cfProj_Fund	link	cfFundProgId	is funded by	PROJ-FUND

Table 4 shows a CERIF publication record where the common and multilingual publication attributes are stored in the upper rows; the lower rows show their relationships (link entities), including a formal contextual semantics. The linkage is established by ids in the attribute column. The type column indicates the entity type, the formal semantic values (Conference Proceedings Article, is part of, is author 1 of, is publisher of, is originator of, is presented at) are stored in the classification column, where each value belongs to a scheme (CERIF2008-RESPUBL-TYPES, RESPUBL-RESPUBL-ROLES, PERS-RESPUBL-ROLES, ORGUNIT-RESPUBL-ROLES).

Table 4: CERIF ResultPublication Example Record

CERIF ResultPublication example database entry					Semantic Layer (CERIF Semantics)	
	Table	Type	Attribute	Classification (ClassIds)	Classification Scheme	
publication-joerg-et-al	cfResPubl	result	cfResPublId			
2008	cfResPubl	result	cfResPublDate			
107	cfResPubl	result	cfStartPage			
123	cfResPubl	result	cfEndPage			
978-961-6133-38-8	cfResPubl	result	cfISBN			
http://www.eurocris.org/fileadmin/Upload/Events/Conferences/CRIS2008/Papers/cris2008_Joerg.pdf	cfResPubl	result	cfURI			
Analyzing European Research Competencies	cfResPublTitle	lang[en.o]	cfTitle			
Results from a European SSA Project	cfResPublSubtitle	lang[en.o]	cfSubtitle			
With this paper we will present the approach of analyzing research competencies across European countries as performed within the EC funded SSA project IST World.	cfResPublAbstr	lang[en.o]	cfAbstr			
IST, ERA, CRIS, CERIF, Research Competencies, NMS, Analysis, Visualisation, Data Cleaning	cfResPublKeyw	lang[en.o]	cfKeyw			
classification-conf-proc-article	cfResPubl_Class	link	cfClassId	Conference Proceedings Article	CERIF2008-RESPUBL-TYPES	
publication-get-the-good-cris-going	cfResPubl_ResPubl	link	cfResPublId2	is part of	RESPUBL-RESPUBL-ROLES	
person-brigitte-joerg	cfPers_ResPubl	link	cfPersId	is author 1 of	PERS-RESPUBL-ROLES	
person-hans-uszkoreit	cfPers_ResPubl	link	cfPersId	is author of	PERS-RESPUBL-ROLES	
person-jure-ferlez	cfPers_ResPubl	link	cfPersId	is author of	PERS-RESPUBL-ROLES	
person-mitja-jermol	cfPers_ResPubl	link	cfPersId	is author of	PERS-RESPUBL-ROLES	
orgunit-izum	cfOrgUnit_ResPubl	link	cfOrgUnitId	is publisher of	ORGUNIT-RESPUBL-ROLES	
project-ist-world	cfProj_ResPubl	link	cfProjId	is originator of	PROJ-RESPUBL-ROLES	
event-cris-2008	cfResPubl_Event	link	cfPersId	is presented at	RESPUBL-EVENT-ROLES	

The CERIF publication entity and its related link entities allow for the generation of complete publication or reference records like BibTeX, as shown in the table 5 below.

Table 5: BibTeX example record generated from table 4 data

```
@article{ ,
  author = {Joerg Brigitte, Uszkoreit Hans, Ferlez Jure, Jermol Mitja},
  title = {Analyzing European Research Competencies in IST: Results from
    a European SSA Project},
  year = {2008},
  isbn = {978-961-6133-38-8},
  pages = {107--123},
  publisher = {IZUM, Institut of Information Science},
  address = {Maribor, Slovenia},
}
```

We have presented the CERIF model in some detail giving emphasis to its mechanism for managing formal contextual semantics in relationships. Moreover, the different examples in contexts show the flexibility of the CERIF Semantic Layer with respect to capturing and maintaining multiple formal schemes to serve particular requests.

4. Related Activities

A survey about standards and formats in the digital library community revealed that there are many different schemas (standards) available in the library domain. Each schema was singularly developed and not designed as an overall architecture to cover integrated object entities. For interoperability and networking in the digital age, the issues of duplicate information - overlap in sections of metadata - need rules that are currently being addressed by good practise guidelines. The resulting report recommends to overcome the problem by best practice guidelines and by pragmatic applications.

The report proposes to structure metadata into:

- **Descriptive:** intellectual content
- **Administrative:** technical (file formats), rights management, provenance (creation, subsequent treatment, responsibility, ...)
- **Structural:** internal structure of items (page, order, ...)

With the survey it was recognized that a combination of metadata standards will always be messier than the utilization of a single standard to combine taxonomic powers and to resolve potential clashes or duplications in between them. Furthermore, the report revealed that integration by itself would be of little consequence if a common standard fails to address the metadata needs of the digital library community [Gartner 2008].

5. Conclusion

The results from the above survey within the library community show that there is increased need for an overarching format to enable quality data integration and interoperability. Not only for a pure data management an overarching standard is of advantage but furthermore for advanced data analysis and to grant access to the information and knowledge contained in different systems. The CERIF format offers a model to structure the research domain into relevant objects and their relationships. Moreover, with the Semantic Layer it provides a powerful means for the management of contextual formal semantics in relationships.

The current interest, usage and applications of the CRIS concept and the CERIF model and interchange format encourage further developments. Next releases will incorporate additional semantics for sub-domains in the context of funding or patents. The priority of next steps will again emerge from requests among euroCRIS members as well as from discussions within the CERIF taskgroup.

6. References

[Bosnjak and Stempfhuber 2008] Bosnjak Ales, Stempfhuber, Maximilian (eds.). Get the Good CRIS Going: Ensuring Quality of Service for the User in the ERA. 9th International Conference on Current Research Information Systems. Maribor, Institute of Information Science, June 2008.

[Asserson and Simons 2006] Asserson, Anne, Simons, E. J. (eds.). Enabling Interaction and Quality: Beyond the Hanseatic League. 8th International Conference on Current Research Information Systems. Bergen, Norway, May 2006. Leuven, Leuven University Press.

[Asserson et al 2002] Asserson, Anne; Jeffery, K.G.; Lopatenko, A.: CERIF: Past, Present and Future: An Overview. In Proceedings: Gaining Insight from Research Information. 6th International Conference on Current Research Information Systems, Kassel, Germany.

[Carpenter 2008] Carpenter, Nicole. Tune it up: Creating and Maintaining the Institutional Repository Revolution. Open and Libraries Class Journal, Vol. 1, No. 1, 2008.

[Chen 1976] Chen, P.P. 1976. The entity-relationship model: Toward a unified view of data. ACM Trans. Database Syst. 1, 1, 9-36.

[EuroHORCS 2008] Window to Science: Information Systems of the European Research Organisations. Report of the EUROHORCS – ESF Working Group on a Joint Research Information System. Strasbourg: European Science Foundation. Report Editing: Alexis-Michel Mugabushaka. ISBN: 2-912049-86-5, October 2008.

[Gartner 2008] Gartner, R. (2008): Metadata for the digital libraries: state of the art and future directions (1.0). Peer reviewed report from the JISC Technology and Standards Watch. April 2008, Bristol, UK.

[Joint 2008] Joint, Nicholas. Current research information systems, open access repositories and libraries. Library Review. 2008, Vol. 57, pp 570-575, Emerald Group Publishing Limited, ISSN: 0024-2535.

[Jeffery and Asserson 2006a] CRIS: Central Relating Information System. In: Asserson A. and Simons, Ed. (eds). Enabling Interaction beyond the Hanseatic League. 8th International Conference on Current Research Information Systems, May 2006, Bergen, Norway, Leuven: Leuven University Press, 109-119.

[Jeffery and Asserson 2006b] Supporting the Research Process with a CRIS. In: Asserson A. and Simons, Ed. (eds). Enabling Interaction beyond the Hanseatic League. 8th International Conference on Current Research Information Systems, May 2006, Bergen, Norway, Leuven: Leuven University Press, 109-119.

[Jeffery et. al. 2002] Jeffery, K.G., Asserson, A.; Lopatenko, A. (2002). Comparative Study of Metadata for Scientific Information: The place of CERIF in CRISs and Scientific Repositories. Gaining Insight from Research Information. 6th International Conference on Current Research Information Systems, Kassel, Germany.

[Jörg et. al. 2008] Jörg, Brigitte; Ferlez, Jure; Uszkoreit, Hans, Jermol, Mitja. Analyzing European Research Competencies in IST: Results from a European SSA Project. In Proceedings: 8th International Conference on Current Research Information Systems. Maribor, June 2008.

[Jörg et. al. 2009] Jörg, Brigitte; Jeffery, Keith; Asserson, Anne; van Grootel, Geert. CERIF 2008 – 1.0 Full Data Model (FDM). Introduction and Specification. euroCRIS, April 2009.

[Jörg et. al. 2009] Jörg, Brigitte; Jeffery, Keith, G.; Asserson, Anne; vanGrootel, Geert; Rasmussen, Henrik; Price, Adrian; Vestam, Thomas; Elbæk, Houssos, Nikos; Voigt, Rita; Simons, E.J. (2009). CERIF 2008 – 1.0 Semantics. euroCRIS, 2009.

[Storey 1993] Storey, V.C. Understanding Semantic Relationships. The International Journal on Very Large Databases (VLDB). Volume 2, Number 4, October 1993, pages 458-488, Springer Berlin-Heidelberg.

[Wand & Weber 2002] Wand, Yair; Weber, Ron. Research Commentary: Information Systems and Conceptual Modeling—A Research Agenda. Information Systems Research Journal, Vol. 13, No. 4, December 2002, pp. 363-376.

[Wang et. al. 1999] Wang, R.Y.; Storey, V.C.; Weber R. An ontological analysis of the relationship construct in conceptual modeling. ACM Transactions on Database Systems (TODS) Journal, Vol. 24, Issue 4, December 1999, pp. 494-528. New York USA.

[UNISIST 1971] Study Report on the Feasibility of a World Science Information System. 171 pages, UNIPUB INC., P.O. Box 433, New York, N.Y.